

# RCD-1 INFORMATION DIAGRAM

**NOTE:** (The RJ-12 6-PIN TO RJ-45 8-PIN CABLE IS THE PROGRAMMING CABLE)  
**THE PROGRAMMING CABLE IS FOR PROGRAMMING ONLY**  
**NOT TO BE USED OR ATTACHED TO A LED DISPLAY**

The RCD-1 must have power to operate from one of the listed Power Options:

**Power Options:**

- 1) Attached to an Adaptive LED Display thru the RJ-45 Receptacle
- 2) Attached to a programming Adaptor thru the RJ-45 Receptacle
- 3) Attached to a 5-volt Power Supply thru the RJ-45 Receptacle
- 4) Attached to a RS- 232 Adaptor thru the RJ-45 Receptacle  
 For use with a computer

When attached to an Adaptive Display:

Use a 6-pin to 6-pin straight thru cable.  
 Attach to the RS-232 Input of the Display.

When using the Relay Option, BUT NOT attached to a LED Display:

Use the Optional 5- volt power supply and the Optional Relay Harness.

When programming the RCD-1:

Use the Optional Programming Adaptor and Cable Kit and attach the 6-pin plug to the DB-9 to RJ-12 Adaptor and the 8-pin plug to the RCD-1's 8-pin RJ-45 receptacle.

**Password** for the programming software is **CD 5580** (ALL Capital Letters).

When using the RCD-1 for viewing the DATA sent to a Cap Code on a computer using Hyper Terminal or ProComm or other software:

Use the Programming Adaptor and attach it as you would to program the RCD-1.

The RJ-45 Receptacle of the RCD-1 unit is for:

- 1) For Communications to the programmer or a Computer.
- 2) For a Power connection from a 5-volt Power Supply or the Programmer Adaptor or an Adaptive LED Display.

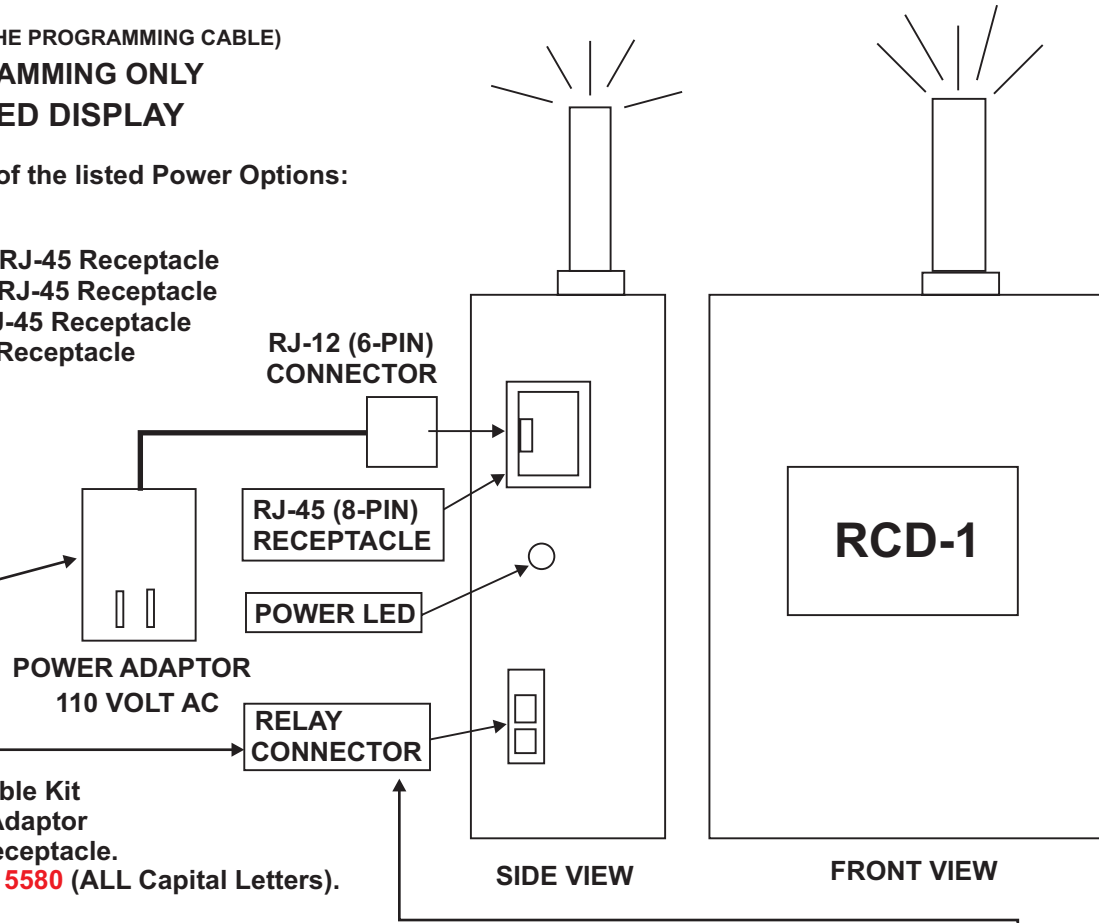

The Relay Harness attaches to the Relay Connector  
 The Relay can be used to control Horns and / or Strobes.

<b>TOLERANCES</b> DECIMAL +/- .015 HOLES +/- .002 ANGLES +/- 1/2°		MATERIAL	FINISH NONE	DATE <b>09-15-05</b>
		TITLE <b>RCD-1 Information Diagram</b>		DWN BY <b>BOB CLYBURN</b>
SCALE None	FIRST USED	WAVEWARE TECHNOLOGIES DALLAS, TEXAS 972-479-1702	DWG. NUMBER	REV. 1