

SHORT HAUL MODEM CONFIGURATION FOR PC TO PAGING SYSTEM

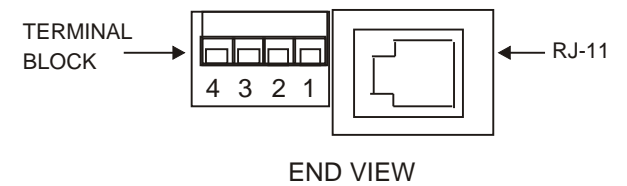

NOTE: WIRES 1-4 ARE REVERSED

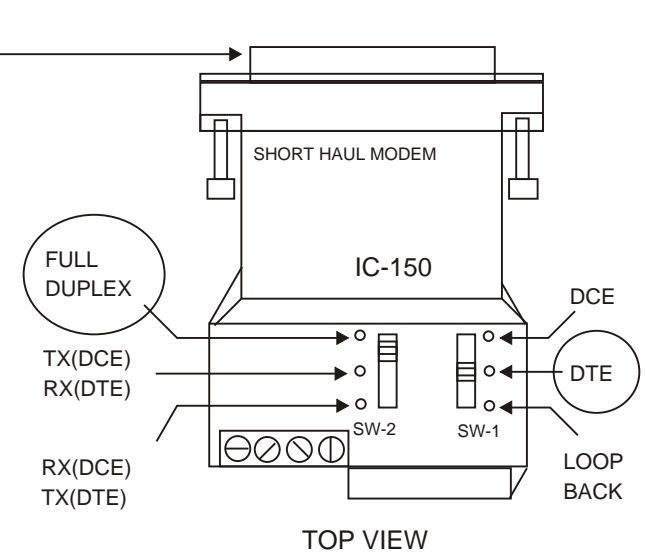
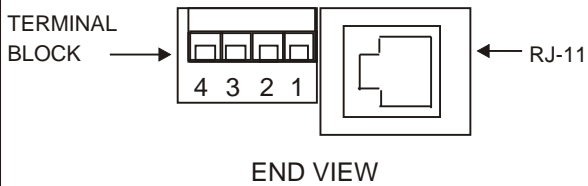
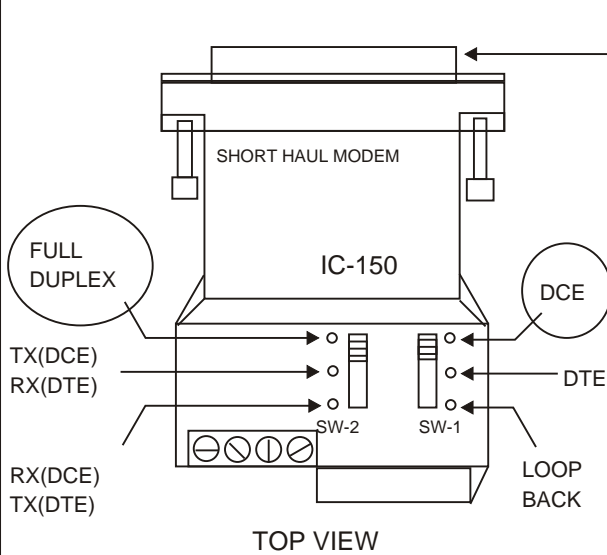
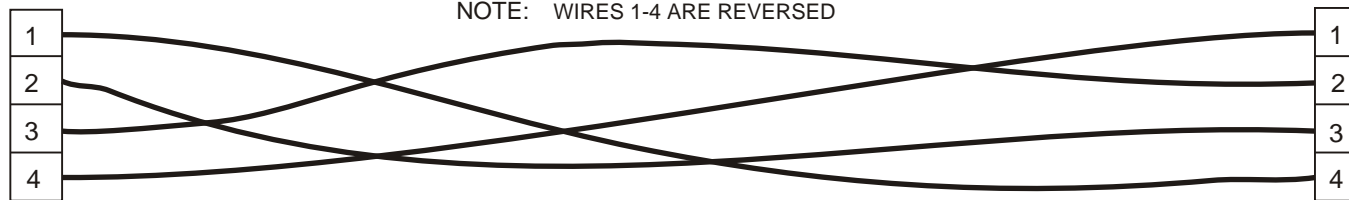

NOTE:
DO NOT USE A
RS-232 MINI TESTER

NOTES:

FOR THE COMPUTER SETTING

- 1: SET SW-2 TO FULL DUPLEX
- 2: SET SW-1 TO DCE

FOR THE PAGING SYSTEM SETTING

- 1: SET SW-2 TO FULL DUPLEX
- 2: SET SW-1 TO DTE

TOLERANCES		MATERIAL	FINISH	DATE
DECIMAL +/- .015			NONE	12-29-03
HOLES +/- .002		TITLE		DWN BY
ANGLES +/- 1/2 °		SHORT HAUL MODEM CONFIGURATION FOR COMPUTER TO PAGING SYSTEM		BOB CLYBURN
SCALE		DWG. NUMBER		REV.
None		WAVEWARE TECHNOLOGIES DALLAS, TEXAS 972-479-1702		1
FIRST USED				APP.